

# Ozgen CDC

## Catalytic Ozone Off Gas destructors CDC40 To CDC100

### Principal of Operation

The Ozgen CDC Series Catalytic Ozone destructors are designed to catalytically convert ozone in contactor off-gas systems to oxygen.

These destructors are self contained units which can operate under pressure from the contact tanks etc. Optionally, a specially designed ventilation fan to extract the off-gas from atmospheric style ozone contact chambers can be fitted

If the ventilation fan is used, then the entire catalytic reaction takes place under negative pressure in the system, with only the de-oxygenated exhaust being under positive pressure. Normally the catalytic destructor is placed above the contact tank on a platform. Should the tank not be covered, it should have a secure, but not necessarily airtight lid attached.

The rated airflow for these destructors is based on a minimum temperature of 10°C. For temperatures below 10°C, select Model and derate the maximum flow 5m<sup>3</sup>/h per °C below 10°C.

The installer need only provide an electrical power source and ozone resistance ducting from the contact tank to the destructor inlet. The ducting material should be PVC, or for extra long life, stainless steel. The airflow is induced through the destructor by pressure or vacuum. Ozonised air flows via the ducting to the inlet of the destructor where it passes over a heating element to raise the temperature to 20°C above ambient. The heated air then passes through a catalyst chamber, which contains beads of a proprietary catalyst. The catalyst, which is based on manganese oxide catalytically, converts the ozone to oxygen. After the catalytic destruction process the de-oxygenated air is discharged to atmosphere.

### Design Features

The Ozgen CDC Series Ozone destructors catalytically decompose at least 99% of the ozone present in a standard atmospheric air stream, irrespective of varying ambient temperatures or humidity. A 316 stainless steel tubular heater heats the ozone containing air, or oxygen.

An automatic thermostat maintains the catalyst bed temperature at 20°C above ambient, therefore the power consumption is directly proportional to the inlet ambient air temperature. All materials in contact with ozone are 316SS or ozone resistance plastics.

The air blower is of cast aluminum construction with Teflon seals. The outer casing of the ozone destructor is 316SS to ensure maximum corrosion resistance.

The Ozgen Catalytic Ozone destructors are designed for easy, reliable installation and operation without the need to monitor and adjust valves or airflows. When selected and installed correctly these units will provide many years of trouble free operation

### Warning

A foam eliminator should be installed prior to the ozone destructor where the possibility of foam may enter the ozone destructor unit.

Model	Ozone/Gas Flow (m <sup>3</sup> /hr)	Min. Ambient Temp (°C)	Power Req. V/pH/Hz	Min/Max Heater kW	Motor kVA	Dimension mm W x H x D	Weight Kg
CDC040	40	0	415/3/50	0.55	1.23	665x2019x631	70
CDC080	80	0	415/3/50	0.7-3.0	0.75	1290x830x680	114
CDC100	100	0	415/3/50	0.7-3.0	0.75	1290x830x680	120

# Ozgen CDC Catalytic Ozone Off Gas Destructors

10	SIDE CHANNEL BLOWER		1
9	CONTROL PANEL		1
8	TEMPERATURE SENSOR		1
7	HEATER ELEMENT		1
6	WATER TRAP	UPVC	2
5	WATER SEPARATOR ASSEMBLY	UPVC	1
4	FOAM SEPARATOR ASSEMBLY	UPVC	1
3	SUPPORT FRAME (FOAM SEPARATOR)	GR 316 S/S	1
2	SUPPORT FRAME (OFF GAS DESTRUCTOR)	GR 316 S/S	1
1	DESTRUCTOR VESSEL	GR 316 S/S	1
ITEM No.	DESCRIPTION	MATERIAL	No. OFF

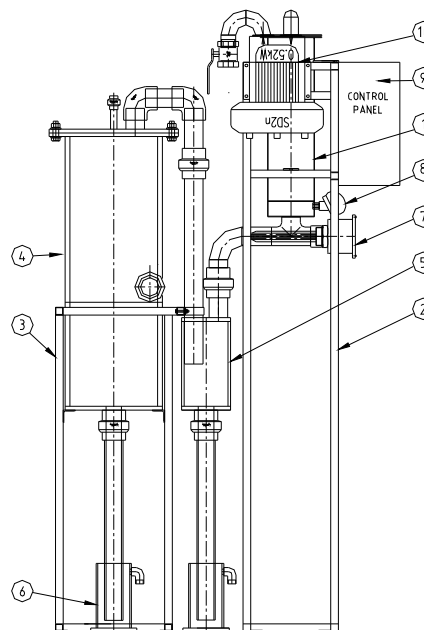

TYPICAL CDC-040



## WATERTEC

### Engineering Pty Ltd

#### Australia

Watertec Engineering Pty. Ltd  
P.O. Box 628  
Waterford,  
Brisbane, QLD,  
Australia, 4133.  
Tel: +61-(0)7-3287-1288  
Fax: +61-(0)7-3287-2800  
Web: [www.watertecengineering.com](http://www.watertecengineering.com)  
Email: [sales@watertecengineering.com](mailto:sales@watertecengineering.com)

#### Malaysia

Waterotec (M) Sdn Bhd  
Lot 5, Jalan Perusahaan 3/3,  
Batu 20, 48000 Rawang,  
Selangor Darul Ehsan  
West Malaysia  
Tel: +603 6092 9029  
Fax: +603 6092 9025  
Web: [www.watertecengineering.com](http://www.watertecengineering.com)  
Email: [sales@waterotec.com](mailto:sales@waterotec.com)